

Perkins

4000 Series

Diesel Engine - Electro Unit

4016TAG2

4016TAG2A

1540 kWm 1200 rev/min

1886 kWm 1500 rev/min

The Perkins 4000 Series family of 8, 12 and 16 cylinder diesel engines was designed in advance of today's uncompromising demands within the power generation industry and includes superior performance and reliability.

The 4016TAG2/2A are turbocharged, air to air charge cooled, 16 cylinder vee form diesel engines. Their premium design and specification features provide economic and durable operation as well as exceptional power to weight ratio, improved serviceability, low gaseous emissions, overall performance and reliability essential to the power generation market. The 4016TAG2A is specially tuned for improved load acceptance response in standby duty.

Economic power

Individual 4 valve cylinder heads give optimised gas flows, while unit fuel injectors ensure ultra fine fuel atomisation and hence controlled rapid combustion for efficiency and economy.

Commonality of components with other engines in 4000 Series family allows reduced parts stocking levels.

Reliable power

Developed and tested using latest engineering techniques.

Piston temperatures are controlled by an advanced gallery jet cooling system.

All engines are tolerant of a wide range of temperatures without derate.

Service is provided through the extensive Perkins network of over 4000 distributors and dealers worldwide.

Clean, efficient power

Exceptional power to weight ratio and compact size for easier transportation and installation.

Designed to provide excellent service access for ease of maintenance.

Engines designed to comply with major international standards.

Low gaseous emissions for cleaner operation.

Engine Speed rev/min	Type of Operation	Typical Generator Output (Net)		Engine Power			
				Gross		Net	
		kVA	kWe	kWm	bhp	kWm	bhp
1200 4016 TAG2	Baseload power	1329	1063	1166	1563	1108	1485
	Prime power	1680	1344	1458	1954	1400	1877
	Standby (maximum)	1848	1478	1598	2148	1540	2065
1500 4016 TAG2A	Baseload power	1868	1495	1413	1894	1362	1826
	Prime Power	2058	1646	1766	2367	1715	2300
	Standby (maximum)	2264	1811	1937	2596	1886	2529

*Note 4016TAG2A is offered for 50Hz operation only

The above ratings represent the engine performance capabilities guaranteed within plus or minus 3% at the reference conditions equivalent to those specified in ISO 8528/1, ISO 3046/1, BS 5514/1.

Ratings conditions: 25°C air inlet temperature, barometer pressure 100kPa, relative humidity 30%. Please consult your distributor or the factory for ratings in ambient conditions.

Note: For full ratings please refer to Perkins Engines Company Limited. All electrical ratings are based on an average alternator efficiency and a power factor of 0.8.

Fuel specification: BS 2869 Class A1 + A2 or ASTM D975 No 2D.

Rating Definitions

Baseload Power - Power available for continuous full load operation. No overload is permitted.

Prime Power - Power available for variable load with an average load factor not exceeding 80% of the prime power rating in any 24 hour period. Overload of 10% permitted for 1 hour in every 12 hours operation.

Standby maximum - Power available at variable load in the event of a main power network failure for a maximum of 500 hours per year. No overload is permitted.

4000 Series

4016TAG2

4016TAG2A

Standard Electro Unit Specification

Air Inlet

Mounted air filters and turbochargers

Fuel System

Unit fuel injectors with lift pump and hand stop control

Electronic governor to ISO 3046 Part 4 class A1

Full-flow spin-on fuel oil filters

Lubrication System

Wet sump with filler and dipstick

Full-flow spin-on oil filters

Engine jacket water/lub. oil temperature stabiliser

Cooling System

Twin gear driven circulating pumps

Two twin thermostats

Crankshaft pulley for fan drive

Electrical Equipment

24V starter motor and 24V/40A alternator with integral regulator and DC output

24V combined high coolant temperature/low oil pressure switch

Overspeed switch and magnetic pickup

Turbine inlet temperature shutdown switch

24V stop solenoid (energised to run)

Flywheel and Housing

Flywheel to SAE J620 size 18

SAE 00 flywheel housing

Optional Equipment

The following optional equipment is available to make up the specifications to Perkins ElectropaK specification:

Tropical radiator including: Water pipes, clips and hoses

Fan, fan guards and belts

Other optional extra equipment available

Twin heavy duty air cleaner – paper element with pre-cleaner

Changeover lubricating oil filters

Changeover fuel oil filters

Immersion heater with thermostat

Water pipes, clips and hoses for radiator

Air starters

Instrument panel

NB This list is not exhaustive, further options may be available to meet to particular applications on enquiry to Perkins Sales Department



Perkins Engines Company Limited

Peterborough PE1 5NA

United Kingdom

Telephone +44 (0)1733 583000

Fax +44 (0)1733 582240

www.perkins.com

All information given in this leaflet is correct at the time of printing but it may be changed subsequently by the Company

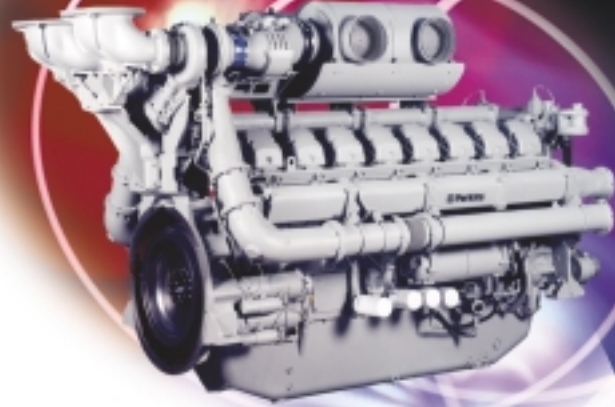

General Data

Number of Cylinders	16	
Cylinder Arrangement	60° Vee form	
Cycle	4-stroke	
Induction System	Turbocharged	
	Air to air charge cooled	
Combustion System	Direct injection	
Cooling System	Water-cooled	
Displacement	61.123 litres	
Bore and Stroke	160mm x 190 mm	
Compression Ratio	13.6:1	
Direction of Rotation	Anti-clockwise, viewed from flywheel end	
Firing Order	1A, 1B, 3A, 3B, 7A, 7B, 5A, 5B, 8A, 8B, 6A, 6B, 2A, 2B, 4A, 4B	
Total Lubrication System Capacity	237.2 litres	
	Electro Unit	ElectropaK
Total Coolant Capacity	95 litres	316 litres
Length	3302 mm	4460 mm
Width	1723 mm	2775 mm
Height	2128 mm	3239 mm
Total Weight (Dry)	5570 kg	8010 kg

Fuel Consumption g/kWh		
Engine speed	1200 rev/min	1500 rev/min
	4016TAG2	4016TAG2A
At Standby Maximum rating	212	212
At Prime Power rating	208	209
At Continuous Baseload rating	207	205
At 75% of Prime Power rating	207	203
At 50% of Prime Power rating	215	202
At 25% of Prime Power rating	251	212

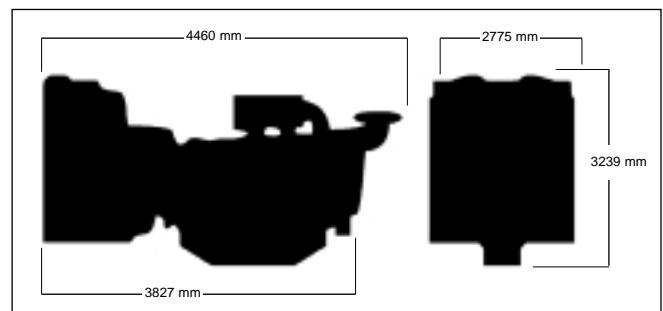

Distributed by