



4000 Series

Diesel Engine - Electro Unit 4012TAG

940 kWm 1200 rev/min
1168 kWm 1500 rev/min



The Perkins 4000 Series family of 8, 12 and 16 cylinder diesel engines was designed in advance of today's uncompromising demands within the power generation industry and includes superior performance and reliability.

The 4012TAG is a turbocharged air to air charge cooled, 12 cylinder vee form diesel engine. Its premium design and specification features provide economic and durable operation as well as exceptional power to weight ratio, improved serviceability, low gaseous emissions, overall performance and reliability essential to the power generation market.

Economic power

Individual 4 valve cylinder heads give optimised gas flows, while unit fuel injectors ensure ultra fine fuel atomisation and hence controlled rapid combustion for efficiency and economy.

Commonality of components with other engines in 4000 Series family allows reduced parts stocking levels.

Reliable power

Developed and tested using latest engineering techniques.

Piston temperatures are controlled by an advanced gallery jet cooling system.

All engines are tolerant of a wide range of temperatures without derate.

Service is provided through the extensive Perkins network of over 4000 distributors and dealers worldwide.

Clean, efficient power

Exceptional power to weight ratio and compact size for easier transportation and installation.

Designed to provide excellent service access for ease of maintenance.

Engines designed to comply with major international standards.

Low gaseous emissions for cleaner operation.

| Engine Speed rev/min | Type of Operation | Typical Generator Output (Net) | | Engine Power | | | |
|-------------------------|----------------------|-----------------------------------|------|--------------|------|------|------|
| | | | | Gross | | Net | |
| | | kVA | kWe | kWm | bhp | kWm | bhp |
| 1200 | Baseload power | 814 | 651 | 702 | 940 | 679 | 910 |
| | Prime power | 1025 | 820 | 877 | 1176 | 854 | 1145 |
| | Standby (maximum) | 1128 | 902 | 963 | 1291 | 940 | 1261 |
| 1500 | Baseload power | 1008 | 807 | 882 | 1182 | 841 | 1127 |
| | Prime Power | 1274 | 1019 | 1102 | 1487 | 1061 | 1422 |
| | Standby (maximum) | 1401 | 1121 | 1209 | 1621 | 1168 | 1566 |

The above ratings represent the engine performance capabilities within plus or minus 3% at the reference conditions equivalent to those specified in ISO 8528/1, ISO 3046/1, BS 5514/1.

Ratings conditions: 25°C air inlet temperature, barometer pressure 100kPa, relative humidity 30%. Please consult your distributor or the factory for ratings in ambient conditions.

Note: For full ratings please refer to Perkins Engines Company Limited. All electrical ratings are based on an average alternator efficiency and a power factor of 0.8.

Fuel specification: BS 2869 Class A1 + A2 or ASTM D975 No 2D.

Rating Definitions

Continuous Baseload – Power available for continuous full load operation. No overload is permitted.

Prime Power – Power available for variable load with an average load factor not exceeding 80% of the prime power rating in any 24 hour period. Overload of 10% permitted for 1 hour in every 12 hours operation.

Standby maximum – Power available at variable load in the event of a main power network failure for a maximum of 500 hours per year. No overload is permitted.

4000 Series 4012TAG

Standard Electro Unit Specification

Air Inlet

Mounted air filters and turbochargers

Fuel System

Unit fuel injectors with lift pump and hand stop control
Electronic governor to ISO 3046 Part 4 class A1
Full-flow spin-on fuel oil filters

Lubrication System

Wet sump with filler and dipstick
Full-flow spin-on oil filters
Engine jacket water/lub. oil temperature stabiliser

Cooling System

Twin gear driven circulating pumps
Two twin thermostats
Crankshaft pulley for fan drive

Electrical Equipment

24V starter motor and 24V/40A alternator with integral regulator and DC output
24V combined high coolant temperature/low oil pressure switch

Overspeed switch and magnetic pickup
Turbine inlet temperature shutdown switch
24V stop solenoid (energised to run)

Flywheel and Housing

Flywheel to SAE J620 size 18
SAE 00 flywheel housing

Optional Equipment

The following optional equipment is available to make up the specifications to Perkins ElectropaK specification:

Tropical radiator including: Water pipes, clips and hoses
Fan, fan guards and belts

Other optional extra equipment available

Twin heavy duty air cleaner – paper element with pre-cleaner
Changeover lubricating oil filters
Changeover fuel oil filters
Immersion heater with thermostat
Water pipes, clips and hoses for radiator
Air starters
Instrument panel

NB This list is not exhaustive, further options may be available to meet to particular applications on enquiry to Perkins Sales Department



Perkins Engines Company Limited

Peterborough PE1 5NA
United Kingdom
Telephone +44 (0)1733 583000
Fax +44 (0)1733 582240
www.perkins.com

All information given in this leaflet is correct at the time of printing but it may be changed subsequently by the Company

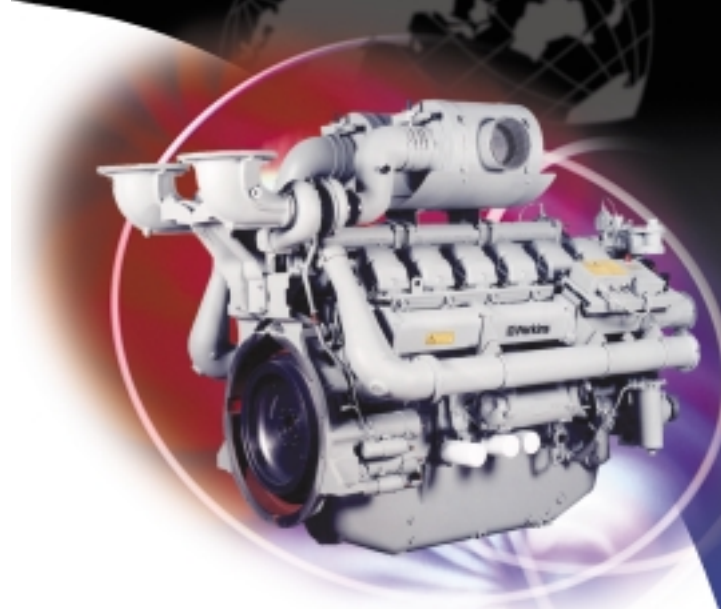

General Data

| | |
|------------------------------|--|
| Number of Cylinders | 12 |
| Cylinder Arrangement | 60° Vee form |
| Cycle | 4-stroke |
| Induction System | Turbocharged |
| | Air to air charge cooled |
| Combustion System | Direct injection |
| Cooling System | Water-cooled |
| Displacement | 45.842 litres |
| Bore and Stroke | 160mm x 190 mm |
| Compression Ratio | 13.6:1 |
| Direction of Rotation | Anti-clockwise, viewed from flywheel end |
| Firing Order | 1A, 6B, 5A, 2B, 3A, 4B, 6A, 1B, 2A, 5B, 4A, 3B |

| | | | |
|--|--------------|---------------------|-------------------|
| Total Lubrication System Capacity | 177.6 litres | Electro Unit | ElectropaK |
| Total Coolant Capacity | 73 litres | | 200 litres |
| Length | 2731 mm | | 3815 mm |
| Width | 1723 mm | | 1890 mm |
| Height | 2118 mm | | 2306 mm |
| Total Weight (Dry) | 4400 kg | | 5280 kg |

| Fuel Consumption g/kWh | | |
|-------------------------------|--------------|--------------|
| Engine speed | 1200 rev/min | 1500 rev/min |
| At Standby Maximum rating | 214 | 207 |
| At Prime Power rating | 211 | 206 |
| At Continuous Baseload rating | 206 | 206 |
| At 75% of Prime Power rating | 206 | 199 |
| At 50% of Prime Power rating | 210 | 204 |
| At 25% of Prime Power rating | 226 | 220 |

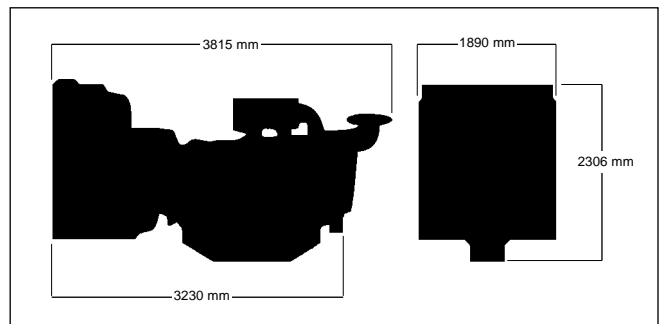

Distributed by