



# 1300 Series EDi

## Diesel engine - Electropak

### 1306-E87TG2

#### 155 kWm 1500 rev/min

The Perkins 1300 Series EDi family of Electropak engines has become renowned throughout the power generation industry for the engines' superior performance and reliability.

The 1306-E87TG2 engine, featuring hydraulically-actuated electronically controlled unit injectors (HEUI) with 'full authority' electronic engine management provides reliable, quiet, economic operation supported by the quick starting, fast response and close control demanded by the electrical power generation market.

### High performance productive power

Hydraulically actuated Electronically controlled Unit Injectors – high-pressure fuel injection gives consistent, reliable high performance. Constant electronic engine management and monitoring enable precise fuel metering and injection timing to ensure reliable low temperature starting, superb economy with performance and very close governing.

### Quiet, clean power

A rigid structure minimises noise transmission and helically cut gears provide quiet power transfer to auxiliaries. Forced induction and electronic fuel injection control combine to reduce combustion noise while electronically optimised fuel/air mixing ensures complete combustion resulting in virtually smoke free operation with emissions capability matching current and future emissions legislation.

### Durable power

A fully balanced induction-hardened steel crankshaft gives smooth performance with minimised bearing loads. Oil cooled pistons with armoured top ring grooves give long life while positive rotational valves and roller cam followers reduce wear on valve seats, tappets and cam lobes.

### Reliable power

Cylinder head coolant is directed to valve bridges and injectors and lubricating oil is cooled in a high efficiency oil cooler, both features enhancing engine reliability. Electronic safety shutdown option protects the engine while event and fault warning codes protect operations.

### Easy maintenance

Electronic diagnostics help to keep the engine at its productive best while enabling the operator to plan maintenance. Oil and filter changes at 450 hours reduce down time. All engines are supported by the Perkins worldwide network of 4,000 distributors and dealers.

Engine Speed (rev/min)	Type of Operation	Typical Generator Output (net)		Engine Power			
				Gross		Net	
		kVA	kWe	kW	bhp	kW	bhp
1500	Baseload Power	147	118	132	177	128	172
Rating Code	Prime Power	163	130	145	195	141	189
M152	Standby (maximum)	178	143	160	215	155	209

The above ratings represent the engine performance capabilities to conditions specified in ISO 8528/1, ISO 3046/1:1986, BS5514/1, DIN 6271.

**Derating may be required for conditions outside these; consult Perkins Engines Company Limited**

Generator powers are typical and are based on an alternator efficiency of 92% and a power factor (cos.  $\theta$ ) of 0.8 Performance tolerance is  $\pm 5\%$

**Fuel specification:** BS 2869: Part 2 1998 Class A2 or ASTM D975 D2

**Lubricating oil:** 15W40 to ACEA E3 or API CG4

#### Rating Definitions

**Baseload power:** Power available for continuous full load operation. Overload of 10% permitted for 1 hour in every 12 hours' operation

**Prime power:** Power available at variable load with a load factor not exceeding 80% of the prime power rating. Overload of 10% is permitted for 1 hour in every 12 hours' operation

**Standby power (maximum):** Power available at variable load in the event of a main power network failure up to a maximum of 500 hours per year of which up to 300 hours may be continuous. No overload is permitted.

# 1300 Series EDi 1306-E87TG2

## Standard ElectropaK Specification

### Air Inlet

Mounted air filter and turbocharger

### Fuel System

Hydraulically actuated electronically controlled unit fuel injectors with full authority electronic control  
Electronic governing to ISO3046-4 with stand alone isochronous or load sharing capabilities  
Spin-on fuel filter with pre-filter and hand primer pump

### Lubrication System

Wet rear well steel sump with filler and dipstick  
Full-flow spin-on filter  
Tube-type oil cooler thermostatically controlled

### Cooling System

Thermostatically controlled system with belt-driven circulating pump and 26 inch belt-driven fan  
Radiator mounted with all guards and pipes  
Coolant filter/conditioner

### Electrical Equipment

24 Volt starter motor and 24 Volt 45 Amp alternator with DC output  
Electronic Control Module mounted on engine with wiring looms and sensors  
3 level engine protection system

### Flywheel and Housing

High inertia flywheel to SAE J620 Size 11½  
Cast iron SAE 2 flywheel housing

### Mountings

Front engine mounting bracket

## Optional Equipment

12V starter and alternator  
12V ECM

Sensor positions for:

- oil pressure
- oil temperature
- coolant temperature

SAE 1 flywheel housing and flywheel  
Turbocharger exhaust outlet  
User's handbook and parts manual  
Workshop manual



### Perkins Engines Company Limited

Peterborough PE1 5NA  
United Kingdom  
Telephone +44 (0)1733 583000  
Fax +44 (0)1733 582240  
[www.perkins.com](http://www.perkins.com)

All information in this leaflet is substantially correct at the time of printing but may be changed subsequently by the Company



## General Data

<b>Number of Cylinders</b>	6
<b>Cylinder Arrangement</b>	Vertical in-line
<b>Cycle</b>	4 stroke
<b>Induction System</b>	Turbocharged
<b>Combustion System</b>	Direct injection
<b>Cooling System</b>	Water-cooled
<b>Bore and Stroke</b>	116.6 x 135.9 mm
<b>Displacement</b>	8.7 litres
<b>Compression Ratio</b>	17.2:1
<b>Direction of Rotation</b>	Anti-clockwise viewed on flywheel
<b>Total Lubrication System Capacity</b>	26.4 litres
<b>Total Coolant Capacity</b>	36.4 litres
<b>Dry Weight (Engine)</b>	855 kg
<b>Length</b>	1737 mm
<b>Width</b>	858 mm
<b>Height</b>	1369 mm

Fuel Consumption		
Engine Speed	1500 rev/min	
	l/hr	Imp gal/hr
At Standby Rating	41.7	9.2
At Prime Power Rating	39.5	8.7
At 75% of Prime Power	32.5	7.2
At 50% of Prime Power	22.2	4.9

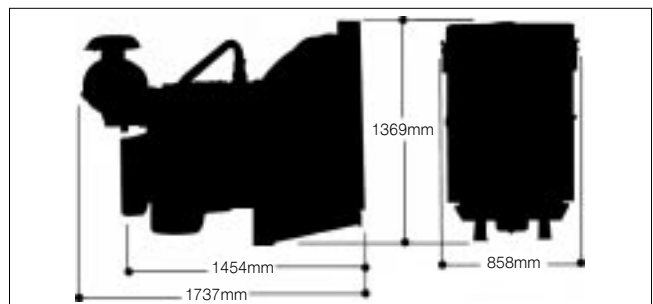

Distributed by